

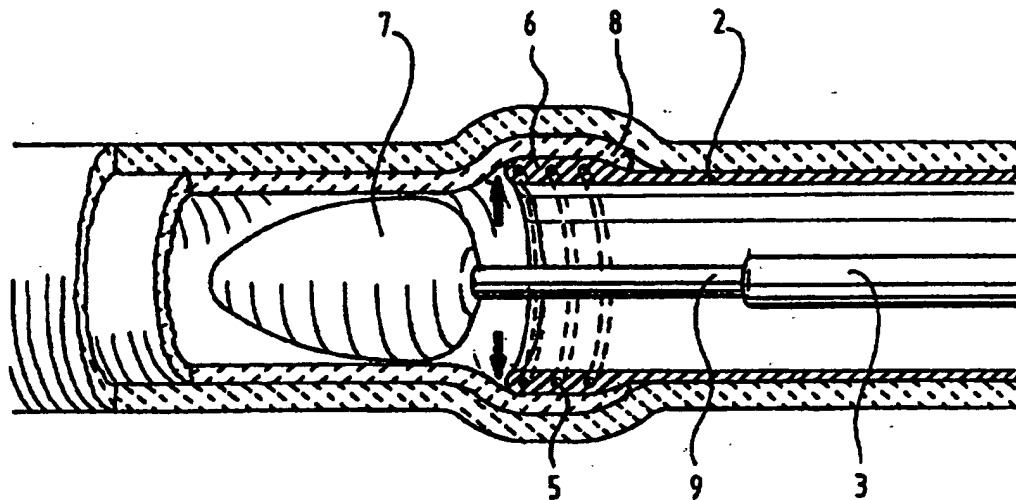

INTERNATIONAL APPLICATION PUBLISHED UNDER THE PATENT COOPERATION TREATY (PCT)

<p>(51) International Patent Classification⁶ : A61F 2/06</p>	<p>A1</p>	<p>(11) International Publication Number: WO 96/10375 (43) International Publication Date: 11 April 1996 (11.04.96)</p>
<p>(21) International Application Number: PCT/NL95/00336 (22) International Filing Date: 4 October 1995 (04.10.95) (30) Priority Data: 9401633 4 October 1994 (04.10.94) NL (71) Applicant (for all designated States except US): CARDIOVASCULAR CONCEPTS, INC. [US/US]; 3260 Alpine Road, Portola Valley, CA 94028 (US). (72) Inventors; and (75) Inventors/Applicants (for US only): KALMANN, Menno [NL/NL]; Hullenkant 45, NL-8075 PD Elspeet (NL). MOLL, Franciscus, Laurens [NL/NL]; Duinweg 21, NL-3735 La Bosch en Duin (NL). (74) Agent: VAN SOMEREN, Petronella, Francisca, Hendrika, Maria; Arnold & Siedsma, Sweelinckplein 1, NL-2517 GK The Hague (NL).</p>		<p>(81) Designated States: JP, US, European patent (AT, BE, CH, DE, DK, ES, FR, GB, GR, IE, IT, LU, MC, NL, PT, SE). Published <i>With international search report.</i></p>

(54) Title: ASSEMBLY FOR TREATING BLOOD VESSELS AND A METHOD THEREFOR



(57) Abstract

The invention relates to a blood vessel treating assembly comprising: an artificial blood vessel inner layer such as an artificial tunica-intima or the like for replacing a section of blood vessel inner layer previously removed from a blood vessel and/or for covering a predetermined length of damaged blood vessel inner layer, wherein said artificial blood vessel inner layer is associated with the existing blood vessel in such a way as to substantially stop any loose parts of the blood vessel from obstructing the stream of blood through said blood vessel; and introducing means for introducing the artificial blood vessel inner layer into the blood vessel.

FOR THE PURPOSES OF INFORMATION ONLY

Codes used to identify States party to the PCT on the front pages of pamphlets publishing international applications under the PCT.

AT	Austria	GB	United Kingdom	MR	Mauritania
AU	Australia	GE	Georgia	MW	Malawi
BB	Barbados	GN	Guinea	NE	Niger
BE	Belgium	GR	Greece	NL	Netherlands
BF	Burkina Faso	HU	Hungary	NO	Norway
BG	Bulgaria	IE	Ireland	NZ	New Zealand
BJ	Benin	IT	Italy	PL	Poland
BR	Brazil	JP	Japan	PT	Portugal
BY	Belarus	KE	Kenya	RO	Romania
CA	Canada	KG	Kyrgystan	RU	Russian Federation
CF	Central African Republic	KP	Democratic People's Republic of Korea	SD	Sudan
CG	Congo	KR	Republic of Korea	SE	Sweden
CH	Switzerland	KZ	Kazakhstan	SI	Slovenia
CI	Côte d'Ivoire	LI	Liechtenstein	SK	Slovakia
CM	Cameroon	LK	Sri Lanka	SN	Senegal
CN	China	LU	Luxembourg	TD	Chad
CS	Czechoslovakia	LV	Latvia	TG	Togo
CZ	Czech Republic	MC	Monaco	TJ	Tajikistan
DE	Germany	MD	Republic of Moldova	TT	Trinidad and Tobago
DK	Denmark	MG	Madagascar	UA	Ukraine
ES	Spain	ML	Mali	US	United States of America
FI	Finland	MN	Mongolia	UZ	Uzbekistan
FR	France			VN	Viet Nam
GA	Gabon				

**ASSEMBLY FOR TREATING BLOOD VESSELS AND
A METHOD THEREFOR**

This invention relates to an assembly for the treating of blood vessels and more specifically to an assembly for the replacing of and/or covering up of damaged, blood vessel inner layers and to a method therefor.

5 An often occurring medical problem is the silting up of blood vessels with for instance calcium, so-called arteriosclerosis. Because of this, a blockage of the blood vessel occurs, so-called stenosis.

Stenosis of blood vessels which leads to a
10 narrowing and, in some cases, complete blocking of the blood vessel can lead to dangerous consequences for the patient. Circulatory problems and a deterioration in health can ensue. Advanced stenosis, if not operated upon, can cause wastage and death of body tissue, necessitating, in certain
15 instances, in amputation.

A known procedure for unblocking blood vessels, 'End artery ectomy', is to separate the inner layer of the blood vessel, the so called tunica-intima, from the blood vessel wall, to cut through and sever the tunica-intima over
20 the blocked length of the bloodvessel and then to remove the tunica-intima plus blockage from the body. A new tunica-intima then grows back to replace this removed tunica-intima.

A problem here is that this new tunica-intima, the
25 so called neo-tunica-intima has the tendency to undergo restenosis, i.e. to silt up again, at a quicker rate than the original tunica-intima.

Another problem is that the original tunica-intima is usually separated from the blood vessel wall upto a
30 distance just past where it is to be severed. Hence on removal of the original tunica-intima, a small piece of this is left hanging loosely in the blood stream, a factor which can cause and hasten the restenosis of the blood vessel.

A blood vessel which is particularly susceptible to stenosis is the artery between the groin and the knee.

It is an object of the present invention to obviate at least one of these problems. To this end there is provided, according to a first aspect of the present invention, a blood vessel treating assembly comprising:

- an artificial blood vessel inner layer such as an artificial tunica-intima or the like for replacing a section of blood vessel inner layer previously removed from the blood vessel and/or for covering a predetermined length of damaged blood vessel inner layer, wherein said artificial blood vessel inner layer is associated with the existing blood vessel in such a way as to substantially withhold any loose parts of the blood vessel from obstructing the stream of blood through said blood vessel, and

- introducing means for introducing the artificial blood vessel inner layer into the blood vessel.

In this way an artificial new tunica-intima to replace the old tunica-intima over the removed length thereof and which prevents the re-growing of a natural 'neo-tunica-intima', can be introduced into a blood vessel, to just past the piece of loose hanging original tunica-intima left after removal of a section of the original tunica-intima for instance, this artificial new tunica-intima made of such material as to cause a minimum of restenosis of the blood vessel to occur and which pushes the old loose hanging piece of left behind tunica-intima back against the blood vessel wall where it re-grows onto the blood vessel wall and thus no longer flaps about in the blood stream.

According to a second aspect of the present invention there is provided an artificial blood vessel inner layer, such as an artificial tunica-intima or the like, made of any suitable synthetic material and comprising diameter arranging means for increasing and/or decreasing the diameter of the tube-like section, preferably for use with the above mentioned assembly.

According to a third aspect of the present invention there is provided introducing means for

introducing an artificial blood vessel inner layer, such as an artificial tunica-intima or the like, into a blood vessel, preferably for use with the assembly and/or the artificial blood vessel inner layer as mentioned above.

5 According to a fourth aspect of the present invention there is provided a method of replacing a previously removed inner layer of a blood vessel and/or for covering a predetermined length of damaged blood vessel inner layer comprising the steps of inserting a blood vessel
10 treating assembly as mentioned above, via an incision, upto a predetermined distance into a blood vessel, increasing the diameter of the artificial blood vessel inner layer to push against the blood vessel walls, whereafter the introducing means are removed and joining the end of the artificial
15 blood vessel inner layer to the existing blood vessel near the incision.

 According to a fifth aspect of the present invention there is provided a method of increasing and/or decreasing the diameter of a length of artificial blood
20 vessel inner layer, as mentioned above, or the like, comprising bringing a length of memory metal associated with the artificial blood vessel inner layer to its preprogrammed activation temperature whereafter expansion/contraction of the memory metal effectively increases/decreases the
25 diameter of the length of artificial blood vessel inner layer.

 According to a further aspect of the present invention there is provided an assembly comprising a tube-like section with at least one length of memory metal
30 associated therewith, pre-programmed to assume a desired form and/or expand and/or contract at a pre-determined activation temperature, and introducing means for introducing the tube-like section into a passage-like area.

 Further advantages, characteristics and details of
35 the present invention will become clear from the following description with reference to the accompanying drawings which show:

Figure 1 a perspective partly cut away view of a preferred embodiment of the assembly according to the present invention, during introduction into the artery between the groin and the knee;

5 Figure 2 a partly cut away perspective view of the artificial blood vessel inner layer of the assembly from figure 1;

Figures 3 to 6 partly cut away perspective views showing the successive steps of the assembly from figure 1
10 carrying out introduction of the artificial blood vessel inner layer from figure 2, into a blood vessel;

Figure 7 a partly cut away perspective view of an embodiment of the artificial blood vessel inner layer according to the present invention, when in position within
15 a blood vessel.

Figures 8 to 9 partly cut away perspective views of a second embodiment of the present invention.

The assembly 1 (figure 1) is introduced into the artery between the groin and the knee, for example,
20 preferably via an incision already made for the removal of the original tunica-intima plus blockage.

This yields the advantage that further incisions for introduction of the assembly into the blood vessel need not be made into the patient, which in turn yields the
25 benefits of reduced stress on the patient, reduced operation and recovery time and accordingly low hospital costs.

The assembly 1 comprises an artificial blood vessel inner layer 2 (see figures 2 to 7) and introducing means for introducing the artificial blood vessel inner
30 layer into the blood vessel.

The introducing means preferably comprise a catheter-like element 3 (see figures 1, 3-6) which is preferably operated from outside of the body (see figure 1).

The artificial blood vessel inner layer 2 (figures
35 2-7), which preferably takes the form of a blood vessel tunica-intima, comprises a tube-like section of synthetic material.

A protective cover is preferably associated with the assembly 1, this preferably taking the form of a removeable sheath 4 (figures 3, 4) which extends from the front of the assembly 1 to the catheter operator.

5 This protective sheath 4 ensures that minimal damage is incurred to the blood vessel wall during introduction of the assembly 1 and that the artificial tunica-intima 2 is substantially protected from any possible interferences which could hinder introduction.

10 Diameter arranging means are preferably associated with the tube-like section of synthetic material, said diameter arranging means preferably being a length of preprogrammed memory metal 5 (figures 2-7). These diameter arranging means are often referred to as a "stent".

15 The tube-like section of the artificial tunica-intima 2 is preferably folded over at its leading end (see figures 2-6), the resulting fold 6 of for example 2 cm preferably enclosing the length of memory metal 5 which preferably takes the form of a coil.

20 The artificial tunica-intima 2 is preferably made of a fluoro carbon polymer, by choice the polymer which goes under the name of teflon, a trademarked name, of Du Pont. Clinical tests have shown that teflon is efficient in ensuring a minimum restenosis of blood vessels.

25 The fact that the coil of memory metal 5 is enclosed as it were in the fold 6 of the artificial tunica-intima 2, means that the memory metal 5 does not come into direct contact with either the blood vessel or the blood stream, so that calcium or any other such blood vessel
30 blocking material is not given a 'foot-hold', on the memory metal, on which it could remain, a factor which further reduces restenosis and/or the rate at which restenosis occurs.

For example, the coil of memory metal can be
35 preprogrammed to increase from a diameter of about 2 mm at room temperature to a diameter of about 8 mm at a temperature of about 35°C in the blood vessel.

The fact that the length of memory metal is preferably in the form of a coil, ensures that a uniform expansion/contraction of the artificial tunica-intima occurs when the preprogrammed temperature of the memory metal is
5 reached.

In use the assembly is inserted into the blood vessel via an incision already made (see figure 1). A guiding wire (not shown) can be introduced into the blood vessel, before introduction of the assembly 1, whereafter
10 the assembly 1 can be pushed over this guiding wire and through the blood vessel.

Blood vessel widening means, for widening the blood vessel during introduction of the assembly, bunging means for blocking off the passage of blood into the
15 assembly during introduction of the assembly into the blood vessel, which could cause introduction complications, and pressure exerting means for pushing the introduced artificial tunica-intima against the blood vessel walls when
in position, are preferably associated with the assembly,
20 and preferably take the form of a cone-like element 7 mounted on the front of the catheter-like element 3 (see figures 3-6).

The cone-shape of the cone-like element 7 enables the assembly 1 to easily follow the passage of the blood
25 vessel, pushing the blood vessel walls apart as it goes in order to facilitate introduction of the assembly 1.

During introduction of the assembly 1, the cone-like element 7 is pushed to a point just past where the old tunica-intima was severed so that the fold 6 of the
30 artificial tunica-intima 2 is encircled by the loose hanging remaining piece of the original tunica-intima 8 (see figures 3-7). At this point forward movement of the assembly 1 is stopped.

The protective sheath 4 is then pulled back off
35 the assembly 1 whilst the assembly 1 itself is held in position (figure 4). The artificial tunica-intima 2, still in its small diameter state, at this point in time, is

relatively tightly wrapped around the catheter-like element 3 (see figure 4).

During withdraw of the protective sheath 4, it was found during clinical tests that the artificial tunica-intima 2 sometimes had the inclination to be pulled back along the catheter-like element 3 together with the sheath 4. In order to prevent this, the catheter-like element 3 can be locally given a somewhat smaller diameter 9 at the position where the memory metal coil 5 is associated with the fold 6 (see figures 3-6), so that the fold 6 and coil of memory metal 5 remain secured in the desired position on withdrawal of the protective sheath 4.

A further feature of the protective sheath is that it aids in insulating the coil of memory metal from the temperature in the blood vessel during introduction of the assembly, so that the coil does not assume its pre-programmed shape until reaching its activation temperature which occurs when the sheath is withdrawn. This prevents the coil from expanding at an undesired position within the blood vessel.

A short period after withdrawal of the protective sheath the coil of memory metal 5 reaches its activation temperature, whereupon the coil of memory metal 5 increases in diameter and so doing pushes the artificial tunica-intima 2 against the walls of the blood vessel (see figure 5).

The artificial tunica-intima 2 pushes the loose hanging piece of remaining old tunica-intima 8 into the blood vessel wall so that this no longer flaps around in the blood stream (see figures 5-7).

The diameter of the artificial tunica-intima 2 is now large enough for the catheter-like element 3, plus the cone-like element 7 to be withdrawn out of the blood vessel, the cone-like element 7 further exerting a certain pressure on the artificial tunica-intima 2 during this withdrawal to further open out and push the latter somewhat into the blood vessel wall (see figure 6).

According to the present invention, it is not necessary to support the artificial tunica-intima over its

whole length, whereby unnecessary added pressure is exerted against the blood vessel wall. The artificial tunica-intima, once in place, is held in position by the blood pressure.

After removal of the sheath 4 and the catheter-
5 like element 3, the artificial tunica-intima 2 can be joined to the blood vessel wall near the incision, preferably by means of stitches. However as shown in figure 7 another possibility to secure the artificial tunica-intima in
10 position within the blood vessel is to equip the artificial tunica-intima with a further coil of memory metal so that the both ends of the artificial section of tunica-intima are forced against blood vessel wall.

After a period of time the artificial tunica-intima grows onto the original blood vessel wall.

15 It will be obvious that during sterilisation, before introduction of the assembly, the memory metal coil should be temporarily held in its small diameter state, by means of for instance a collar, so that it does not assume its preprogrammed expanded form at this stage.

20 A further embodiment of the present invention is shown in figures 8 and 9.

In this embodiment 20, the length of preprogrammed memory metal, is replaced by a section of gauze-like material 21 (figures 8 and 9), enclosed within an end
25 section 22 of the artificial tunica-intima.

The end section 22 and artificial intima-tunica are pushed over an expandible balloon 23 and a protective sheath, not shown, is brought thereover. Following
30 introduction, the sheath is removed and the balloon 23 expanded to force the end section 22 against the wall of the blood vessel, whereby it is held in position by the stent 21, to affix with the blood vessel wall. Blood pressure forces the length of unsupported artificial intima-tunica to affix with the blood vessel wall as in the first embodiment.
35 Following positioning, the balloon 23 is removed.

This stent 21 is preferably made from stainless steel.

The artificial tunica-intima is required to be supple, and have elastic and anti-thrombogenic qualities and is preferably porous, in order to mimic the qualities of the tunica-intima. A suitable material herefor is
5 polytetrafluorethylene made by Dacron.

The material for the artificial tunica-intima can be supplied with endothelial cells in order to further enhance its working as a tunica-intima.

Although the present invention refers to the
10 introduction and placing of an artificial intima tunica, intima tunicas from the patient self and from donors may be introduced and arranged in position according to the present invention.

The present invention thus yields a simple yet
15 efficient introduction of a new artificial inner blood vessel layer, which can be carried out in a short time and with a minimum of discomfort to the patient.

The present invention is not limited to the hereabove described and illustrated embodiments, rather
20 within the range of the following claims, a large number of modifications and variations are conceivable.

CLAIMS

1. A blood vessel treating assembly comprising:
 - an artificial blood vessel inner layer such as an artificial tunica-intima or the like for replacing a section of blood vessel inner layer previously removed from
5 a blood vessel and/or for covering a predetermined length of damaged blood vessel inner layer, wherein said artificial blood vessel inner layer is associated with the existing blood vessel in such a way as to substantially stop any loose parts of the blood vessel from obstructing the stream
10 of blood through said blood vessel, and
 - introducing means for introducing the artificial blood vessel inner layer into the blood vessel.
2. A blood vessel treating assembly according to claim 1, further comprising at least one sheath-like
15 protective cover.
3. An artificial blood vessel inner layer such as an artificial tunica-intima or the like, comprising at least one tube-like section of synthetic material, and diameter arranging means for increasing and/or decreasing the
20 diameter of the tube-like section.
4. An artificial blood vessel inner layer according to claim 3 wherein the diameter arranging means is at least one length of memory metal associated with the tubelike section, preprogrammed to expand and/or contract at
25 a determined temperature.
5. An artificial blood vessel inner layer according to claims 3 or 4 wherein the memory metal is associated with the artificial blood vessel inner layer in such a way that when said artificial blood vessel inner
30 layer is in position within a blood vessel, said artificial blood vessel inner layer substantially stops blood flowing through the blood vessel from coming into contact with the memory metal.

6. Introducing means for introducing an artificial blood vessel inner layer, or the like, into a blood vessel, or the like, wherein the introducing means comprises at least one catheter-like element associated with the
5 artificial blood vessel inner layer.

7. A blood vessel treating assembly according to claims 1 or 2, further comprising widening means for widening out of the blood vessel in order to facilitate introduction of the blood vessel treating assembly therein.

10 8. A blood vessel treating assembly according to claims 1, 2 or 7 further comprising bunging means for substantially blocking off the passage of blood into the assembly during introduction of the assembly into the blood vessel.

15 9. A blood vessel treating assembly according to claims 1, 2, 7 or 8 further comprising pressure exerting means for exerting pressure onto the artificial blood vessel inner layer, when the latter is in position within the blood vessel.

20 10. A blood vessel treating assembly according to claims 1, 2, 7, 8 or 9 wherein the blood vessel widening means, the bunging means and the pressure exerting means take the form of at least one cone-shaped element associated with the front of the introducing means.

25 11. A blood vessel treating assembly according to the claims 1, 2, 7-10, provided with an artificial blood vessel inner layer according to claims 3 to 5 and introducing means according to claim 6.

30 12. A method of replacing a previously removed inner layer of a blood vessel and/or for covering a predetermined length of damaged blood vessel inner layer comprising the steps of inserting a blood vessel treating assembly according to claim 11, via an incision, upto a predetermined distance into a blood vessel, removing the
35 protective sheath from around the assembly whereafter the memory metal expands on reaching its preprogrammed activation temperature to push the artificial blood vessel inner layer against the blood vessel walls, the catheter-

like element then being removed from the blood vessel, the conelike element further forcing the artificial blood vessel inner layer into position as it does so, and joining the end of the artificial blood vessel inner layer to the existing
5 blood vessel near the incision.

13. A method of increasing and/or decreasing the diameter of a length of artificial blood vessel inner layer, according to claims 3 to 5, or the like, comprising bringing the memory metal associated with the artificial blood vessel
10 inner layer to its preprogrammed activation temperature whereafter expansion/contraction of the memory metal effectively increases/decreases the diameter of the length of artificial blood vessel inner layer.

14. Assembly comprising a tube-like section with
15 at least one length of memory metal associated therewith, pre-programmed to assume a desired form and/or expand and/or contract at a pre-determined activation temperature, and introducing means for introducing the tube-like section into a passage-like area.

1/5

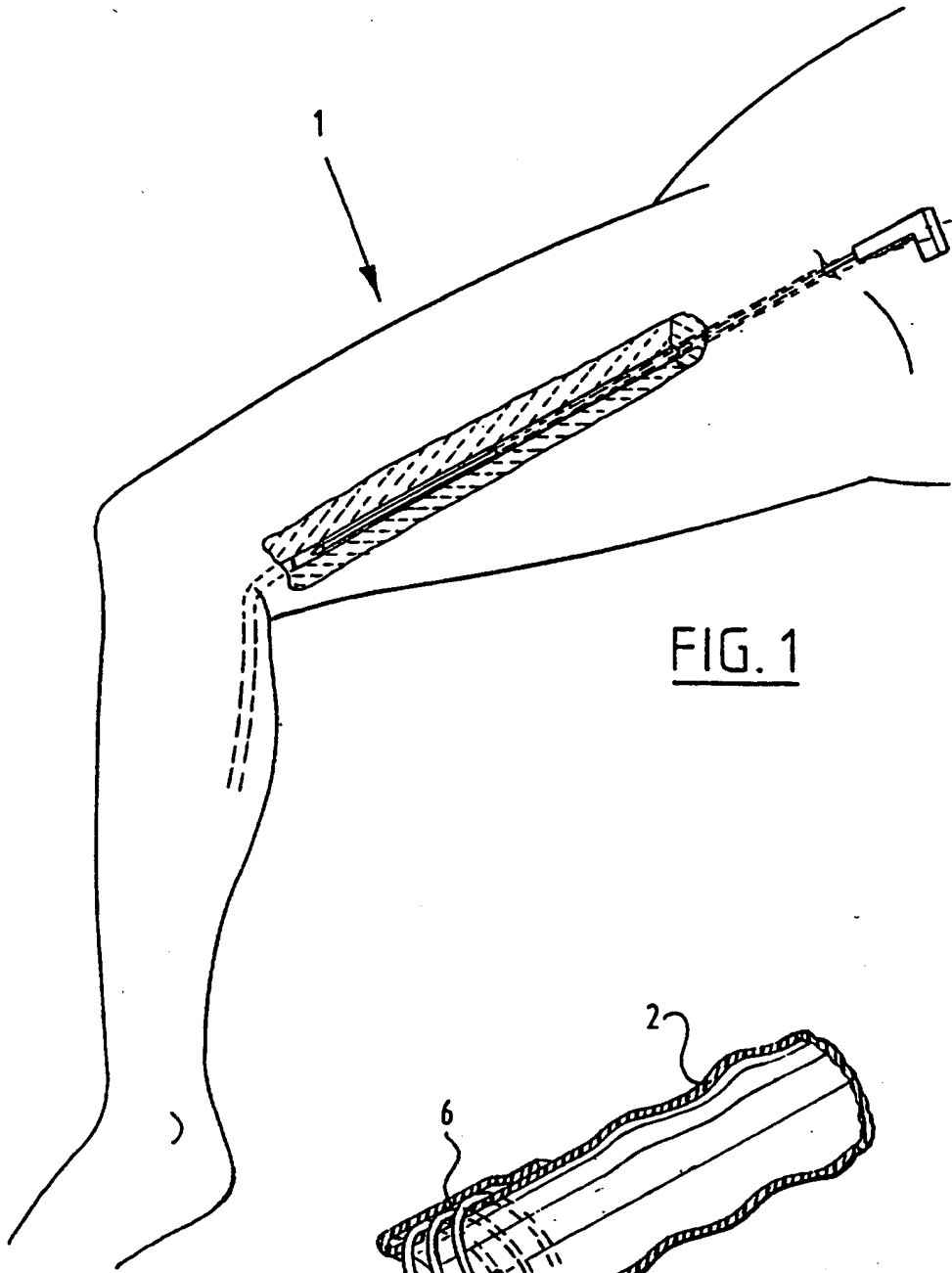

FIG. 1

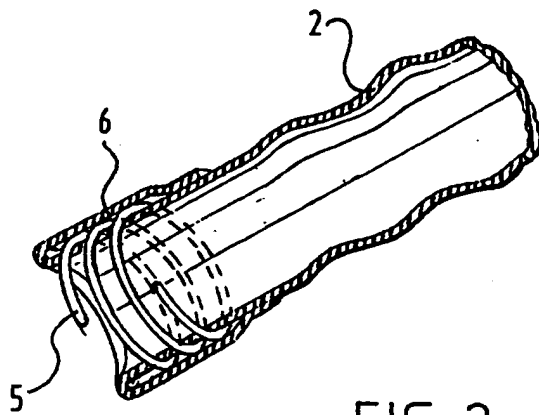

FIG. 2

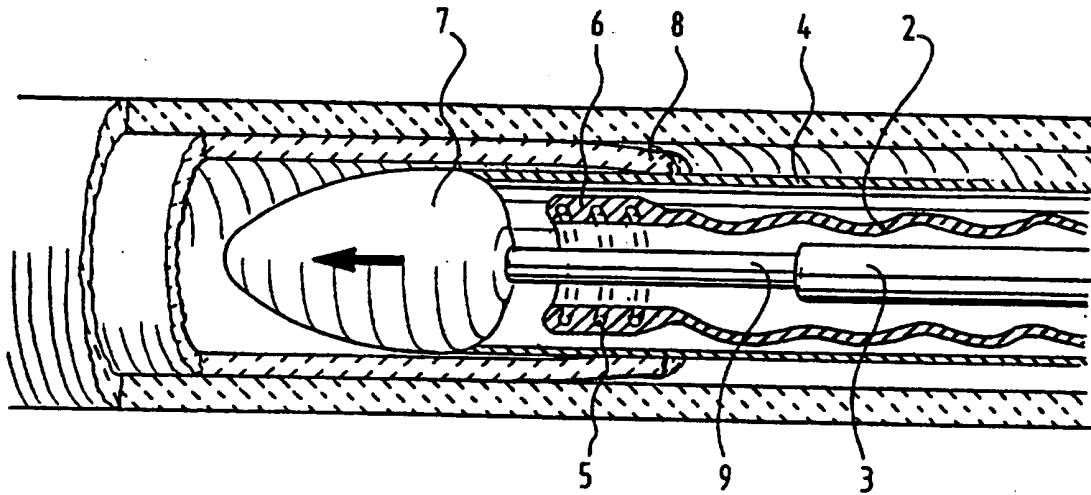

FIG. 3

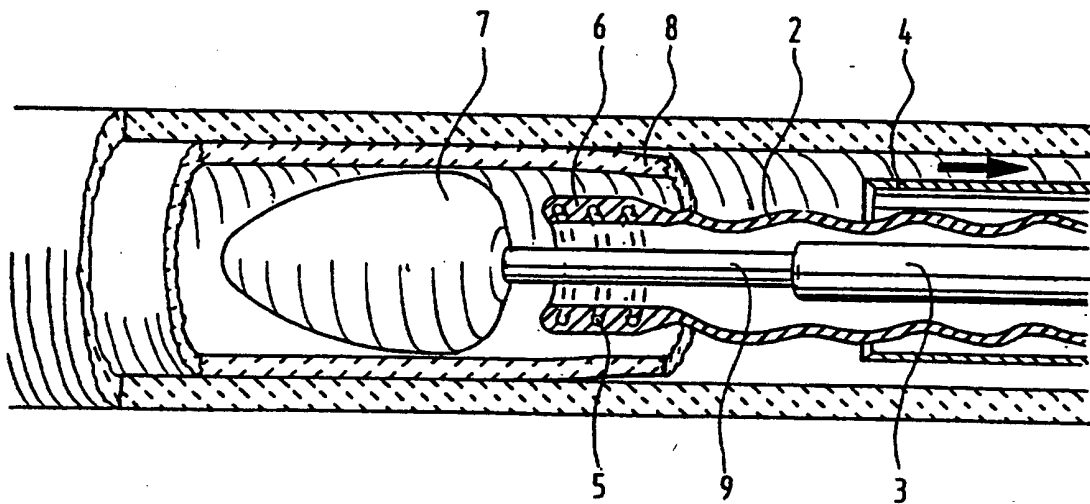

FIG. 4

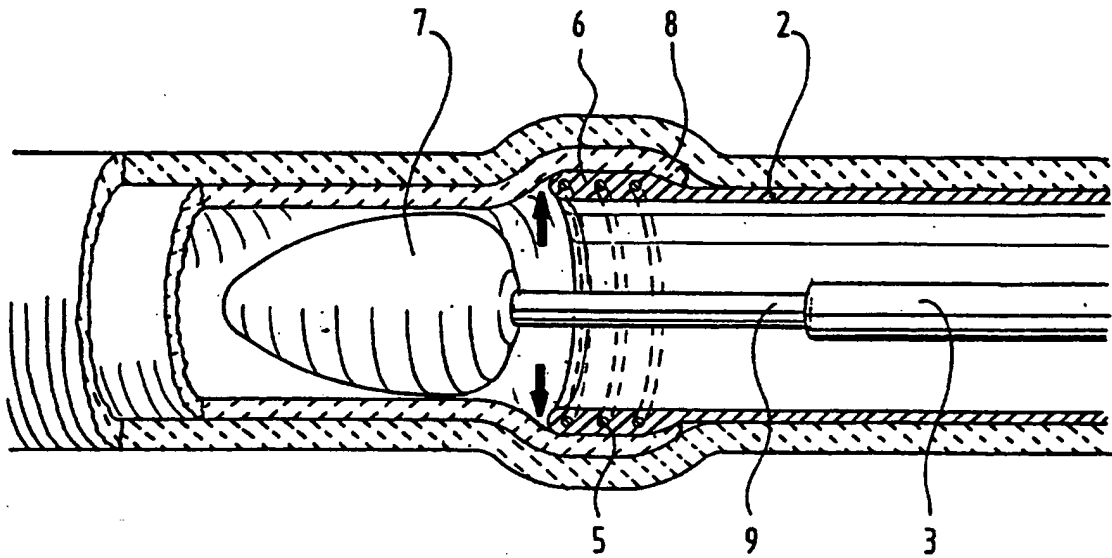

FIG. 5

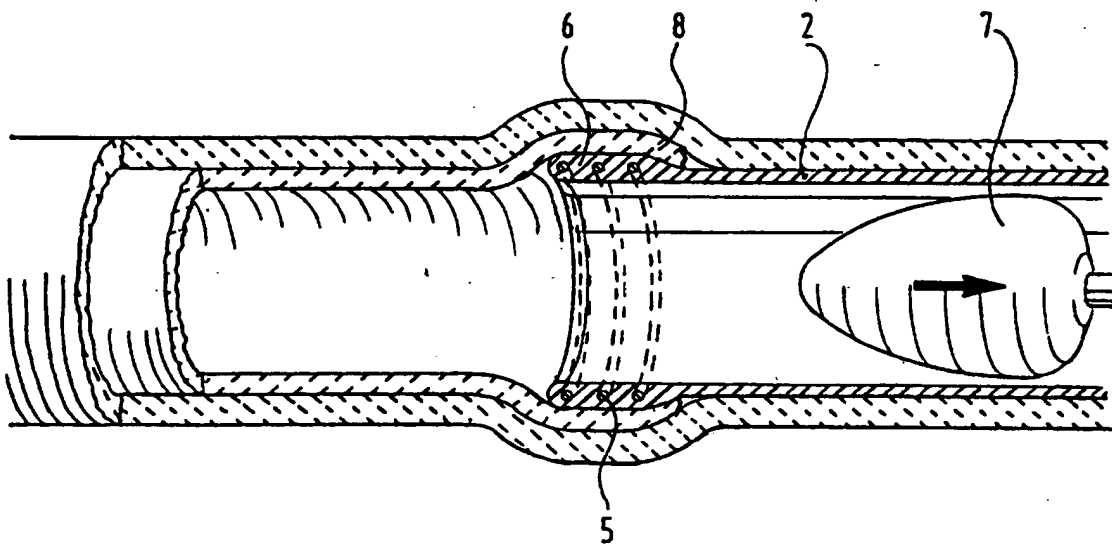

FIG. 6

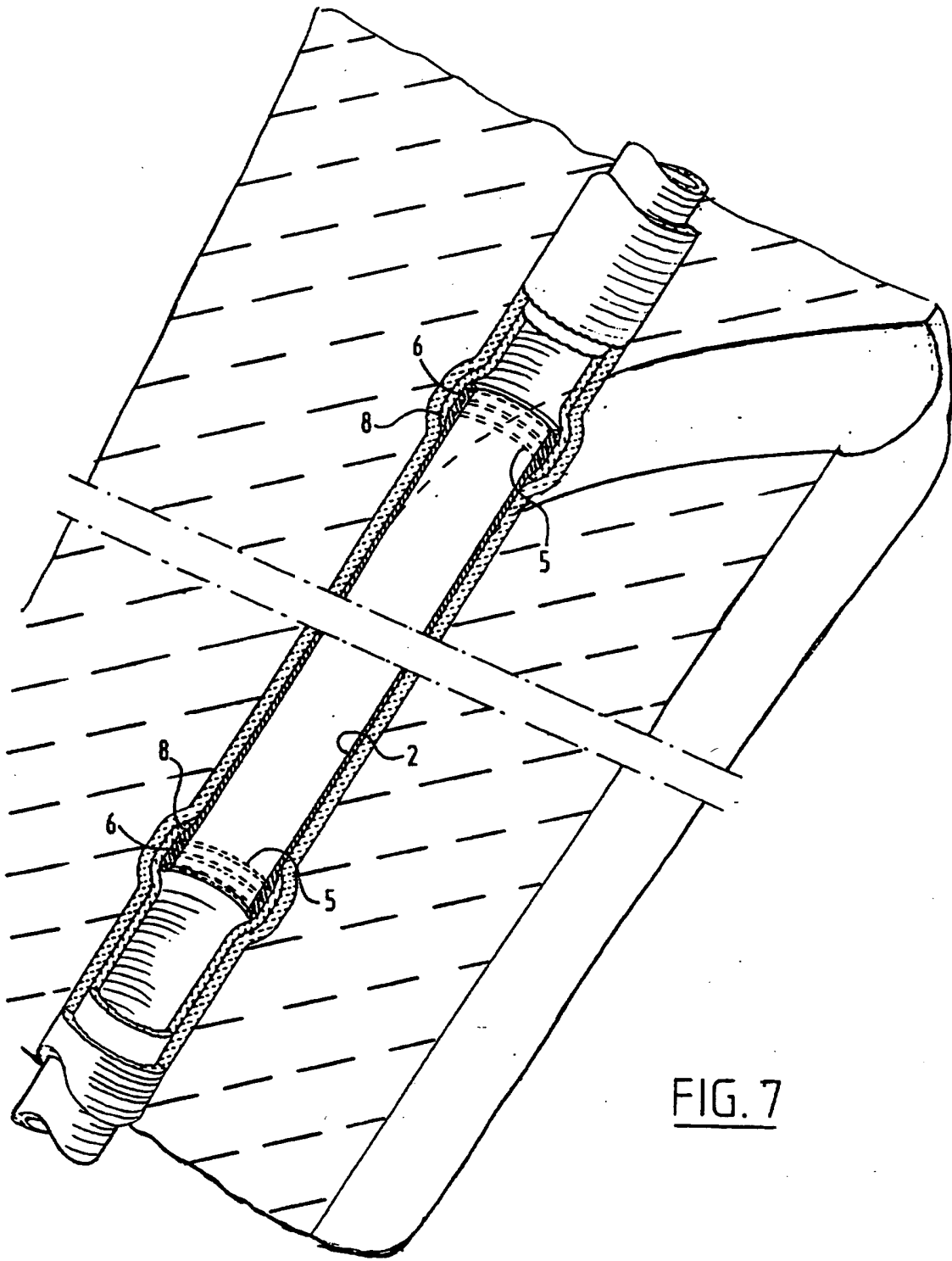

FIG. 7

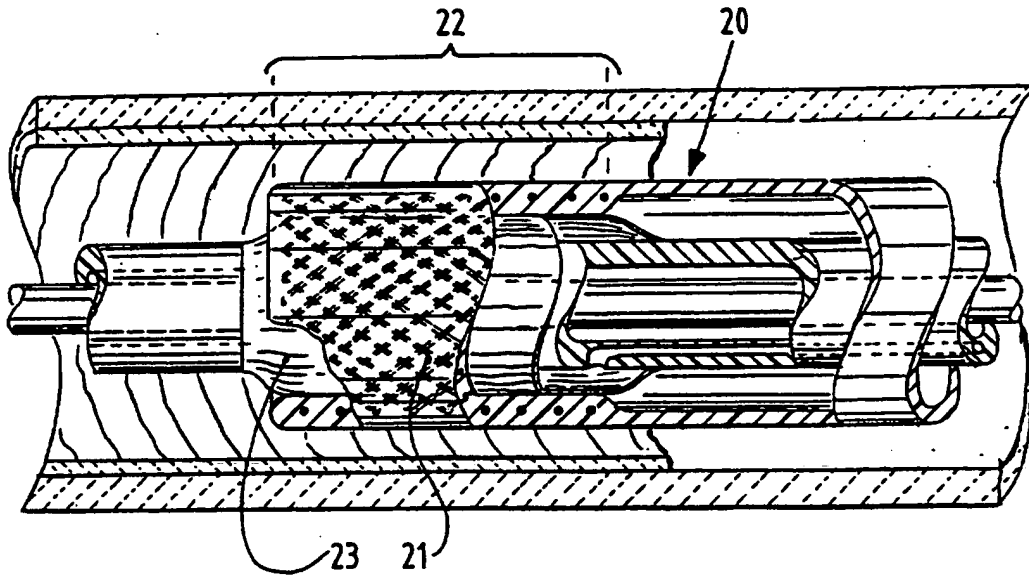

FIG. 8

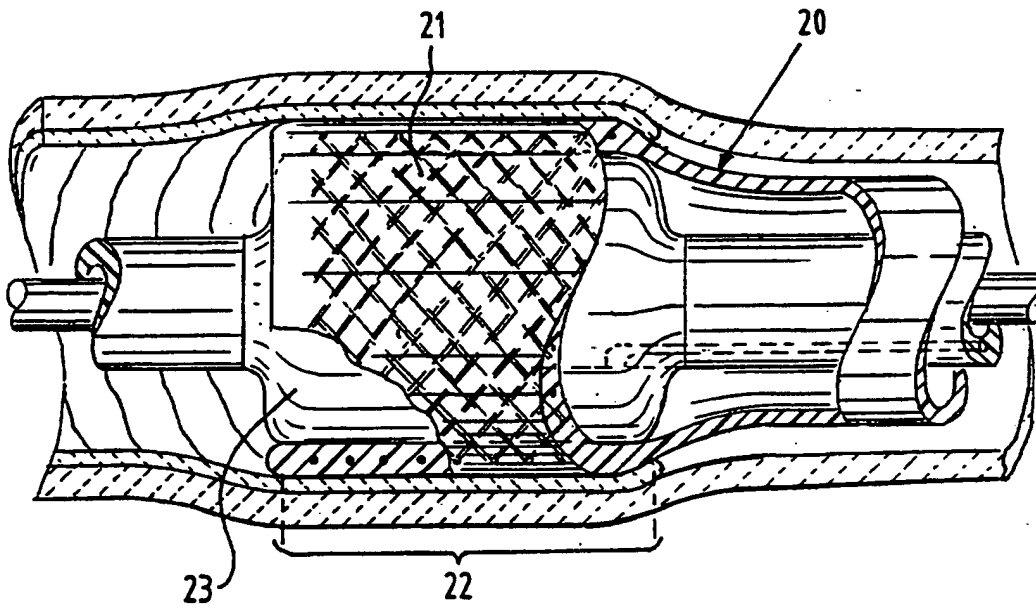

FIG. 9

INTERNATIONAL SEARCH REPORT

International Application No
PCT/NL 95/00336

A. CLASSIFICATION OF SUBJECT MATTER
IPC 6 A61F2/06

According to International Patent Classification (IPC) or to both national classification and IPC

B. FIELDS SEARCHED

Minimum documentation searched (classification system followed by classification symbols)

IPC 6 A61F

Documentation searched other than minimum documentation to the extent that such documents are included in the fields searched

Electronic data base consulted during the international search (name of data base and, where practical, search terms used)

C. DOCUMENTS CONSIDERED TO BE RELEVANT

Category *	Citation of document, with indication, where appropriate, of the relevant passages	Relevant to claim No.
X	WO,A,94 04096 (NOVADIS) 3 March 1994	1-6, 9, 11, 13, 14
Y	see abstract; figures see page 5, line 15-20 ---	7, 8, 10
X	EP,A,0 119 688 (BALKO) 26 September 1984 see the whole document ---	1-6, 9, 11, 13, 14
Y	US,A,4 665 918 (BOSTON SCIENTIFIC CORP.) 19 May 1987 see abstract; figures 9-13 ---	7, 10
Y	WO,A,90 01969 (SLEPIAN) 8 March 1990 see figures 13A-D ---	8
A	EP,A,0 274 846 (ADVANCED SURGICAL INTERVENTION INC.) 20 July 1988 -----	

Further documents are listed in the continuation of box C.

Patent family members are listed in annex.

* Special categories of cited documents :

- *A* document defining the general state of the art which is not considered to be of particular relevance
- *E* earlier document but published on or after the international filing date
- *L* document which may throw doubts on priority claim(s) or which is cited to establish the publication date of another citation or other special reason (as specified)
- *O* document referring to an oral disclosure, use, exhibition or other means
- *P* document published prior to the international filing date but later than the priority date claimed

- *T* later document published after the international filing date or priority date and not in conflict with the application but cited to understand the principle or theory underlying the invention
- *X* document of particular relevance; the claimed invention cannot be considered novel or cannot be considered to involve an inventive step when the document is taken alone
- *Y* document of particular relevance; the claimed invention cannot be considered to involve an inventive step when the document is combined with one or more other such documents, such combination being obvious to a person skilled in the art.
- *&* document member of the same patent family

Date of the actual completion of the international search

9 January 1996

Date of mailing of the international search report

18. 01. 96

Name and mailing address of the ISA

European Patent Office, P.B. 5818 Patentlaan 2
NL - 2280 HV Rijswijk
Tel. (+ 31-70) 340-2040, Tx. 31 651 epo nl,
Fax: (+ 31-70) 340-3016

Authorized officer

Steenbakker, J

INTERNATIONAL SEARCH REPORT

national application No.

PCT/NL95/00336

Box I Observations where certain claims were found unsearchable (Continuation of item 1 of first sheet)

This international search report has not been established in respect of certain claims under Article 17(2)(a) for the following reasons:

1. Claims Nos.: 12
because they relate to subject matter not required to be searched by this Authority, namely:
PCT Rule 39.1 (iv)
2. Claims Nos.:
because they relate to parts of the international application that do not comply with the prescribed requirements to such an extent that no meaningful international search can be carried out, specifically:
3. Claims Nos.:
because they are dependent claims and are not drafted in accordance with the second and third sentences of Rule 6.4(a).

Box II Observations where unity of invention is lacking (Continuation of item 2 of first sheet)

This International Searching Authority found multiple inventions in this international application, as follows:

1. As all required additional search fees were timely paid by the applicant, this international search report covers all searchable claims.
2. As all searchable claims could be searched without effort justifying an additional fee, this Authority did not invite payment of any additional fee.
3. As only some of the required additional search fees were timely paid by the applicant, this international search report covers only those claims for which fees were paid, specifically claims Nos.:
4. No required additional search fees were timely paid by the applicant. Consequently, this international search report is restricted to the invention first mentioned in the claims; it is covered by claims Nos.:

Remark on Protest

 The additional search fees were accompanied by the applicant's protest. No protest accompanied the payment of additional search fees.

INTERNATIONAL SEARCH REPORT

Information on patent family members

International Application No
PCT/NL 95/00336

Patent document cited in search report	Publication date	Patent family member(s)	Publication date
WO-A-9404096	03-03-94	FR-A- 2694688	18-02-94
EP-A-0119688	26-09-84	US-A- 4512338	23-04-85
US-A-4665918	19-05-87	NONE	
WO-A-9001969	08-03-90	AT-T- 121954	15-05-95
		AU-B- 4191989	23-03-90
		CA-A- 1336755	22-08-95
		DE-D- 68922497	08-06-95
		DE-T- 68922497	14-09-95
		EP-A- 0431046	12-06-91
		EP-A- 0649637	26-04-95
		JP-T- 4501670	26-03-92
		US-A- 5213580	25-05-93
EP-A-0274846	20-07-88	US-A- 4893623	16-01-90
		US-A- 4762128	09-08-88
		AU-B- 649650	02-06-94
		AU-B- 7120091	02-05-91
		AU-B- 7120191	02-05-91
		AU-B- 609431	02-05-91
		AU-B- 8210087	09-06-88
		DE-D- 3789053	24-03-94
		DE-T- 3789053	11-08-94
		ES-T- 2049219	16-04-94
		JP-A- 63214264	06-09-88
		US-A- 5312430	17-05-94
		ZA-A- 8709207	06-06-88